

**STEP 1:** Insert strap through tightening buckle.

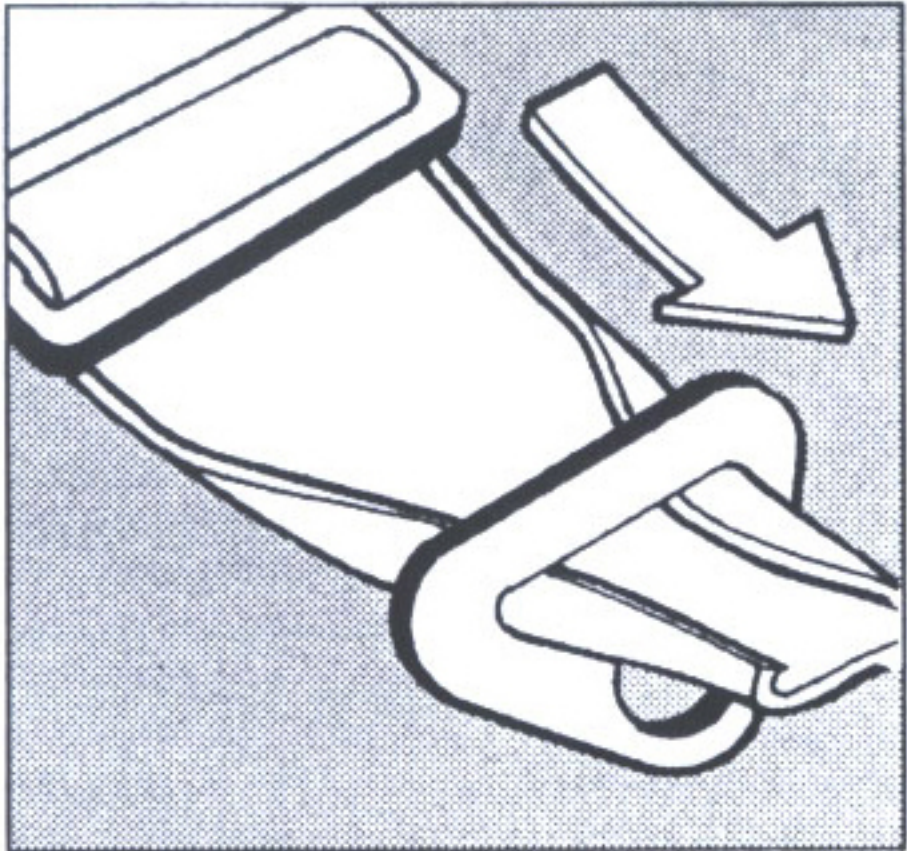

**STEP 2:** Pull strap to 8"-10" beyond buckle, fold edges and insert into mounting bracket.

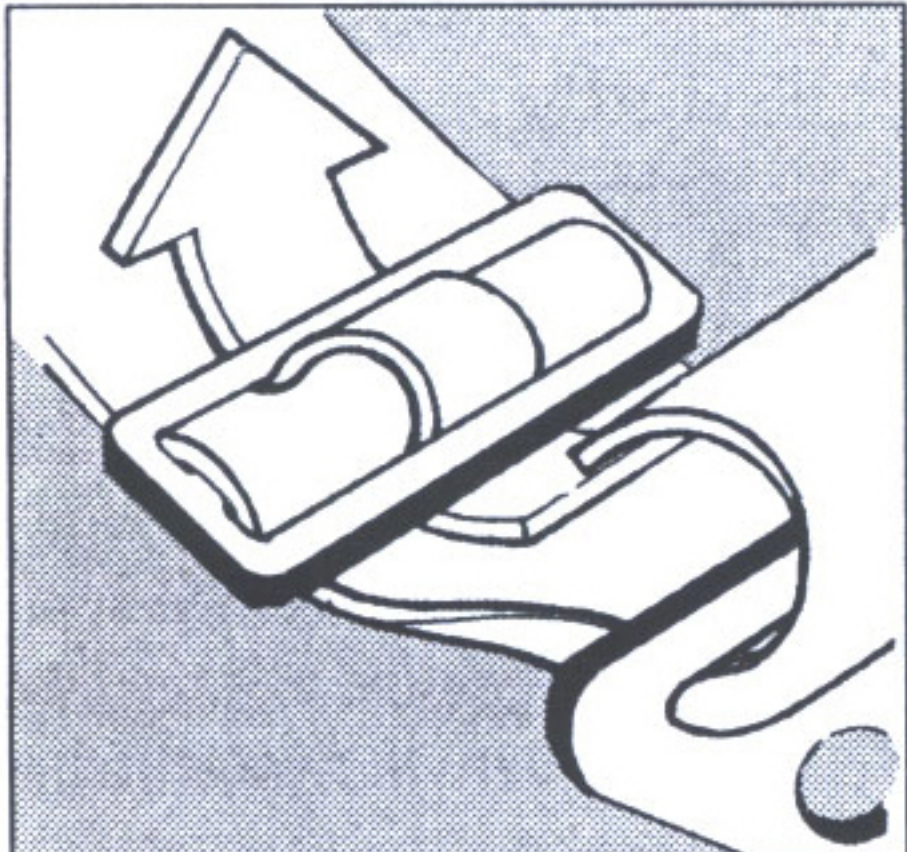

**STEP 3:** Fold back strap and re-insert through buckle as shown.

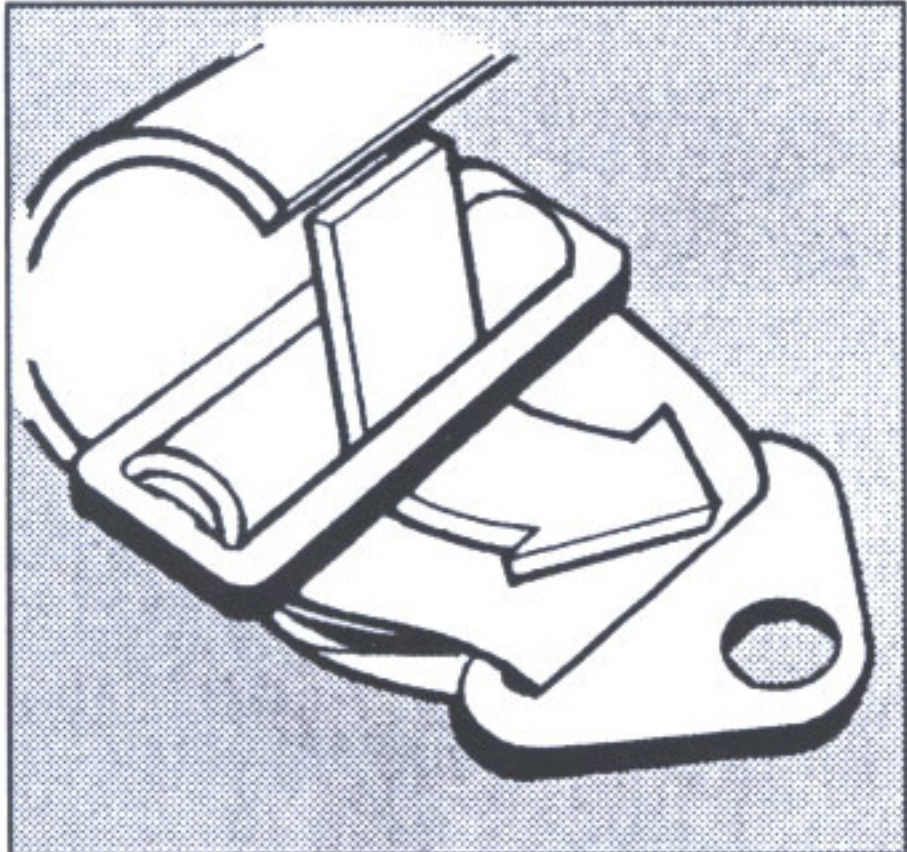

**STEP 4:** Fold back strap again and insert through bottom portion of buckle.